

# CHAINS

and SPROCKETS for the  
**CEMENT INDUSTRY**

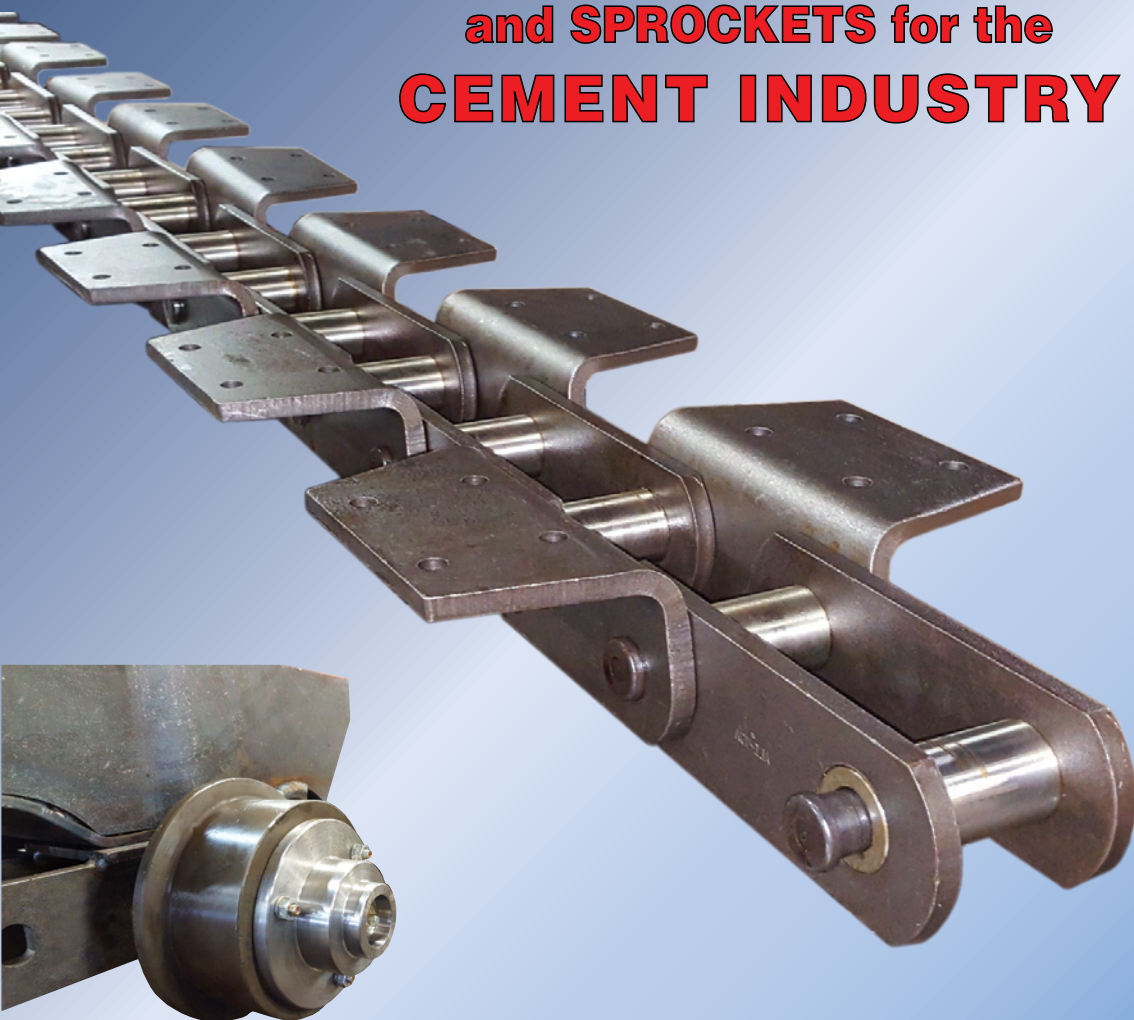

**ALLIED-LOCKE**

*Proudly Manufacturing in the U.S.A. Since 1965*

[www.alliedlocke.com](http://www.alliedlocke.com)

# HEAVY DUTY CEMENT ELEVATOR CHAIN

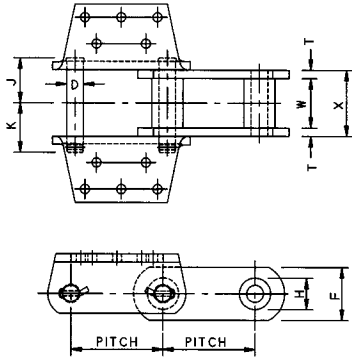
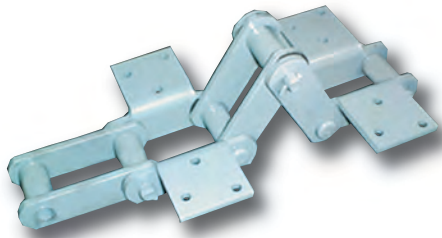

**ALLIED-LOCKE Heavy Duty SS Class Steel Bushed Chains** are designed and constructed to withstand the rigorous conditions encountered in cement mill elevators and to provide the service life expected by the cement industry.

CHAIN NUMBER	PITCH	D	F	H	J	K	T	W	X	STANDARD ATTACHMENTS
SS856	6.000	1.00	2.50	1.75	2.91	3.16	.50	3.00	4.00	K2, K3, K24, K35
SS956	6.000	1.00	3.00	1.75	2.78	3.16	.50	3.00	4.00	K24
SS857	6.000	1.00	3.25	1.75	2.81	3.12	.50	3.00	4.00	K44
SS859	6.000	1.25	4.00	2.38	3.44	3.81	.62	3.75	5.00	K44
SS958	6.000	1.12	3.25	2.00	3.09	3.24	.56	3.00	4.12	K44
SS958SJ	6.000	1.12	3.25	2.00	3.34	3.49	.56	3.00	4.12	K44
SS864	7.000	1.25	4.00	2.38	3.44	3.81	.62	3.75	5.00	K443
SS864SJ	7.000	1.25	4.00	2.38	3.64	4.11	.62	3.75	5.00	K443
SS984	7.000	1.38	4.00	2.50	3.41	3.84	.62	3.75	5.00	K443
SS984SJ	7.000	1.38	4.00	2.50	3.66	4.09	.62	3.75	5.00	K443
SS994	7.000	1.58	4.00	2.50	3.41	3.84	.62	3.75	5.00	K443
SS994SJ	7.000	1.58	4.00	2.50	3.66	4.09	.62	3.75	5.00	K443
SS833	6.000	.75	2.00	1.44	2.38	2.72	.38	2.62	3.38	K2FW

\* SJ denotes chains available with sealed joints.

## 800 and 900 Series Elevator Chains

The original 800 Series Elevator Chains were introduced over 50 years ago. They were developed to offer additional strength and wear resistance, allowing elevators to be built taller and run with larger capacities than ever before. Allied-Locke has continuously worked on improving the performance of our 800 Series through our manufacturing methods and test programs.

The 900 Series was developed to provide more strength, allowing even greater loads. These chains are constructed with larger components to provide a minimum of 30% greater fatigue strength. This greater strength may be utilized for building greater capacity elevators in new construction or as a solution to handling greater loads in existing elevators.

The 900 Series is designed to interchange with the 800 Series. See comparisons at right.

SS856 vs. SS956

SS857 vs. SS958

SS864 vs. SS984

Operates on same traction wheel and sprocket. Bucket hole spacing is identical. Up to 30% greater fatigue strength.

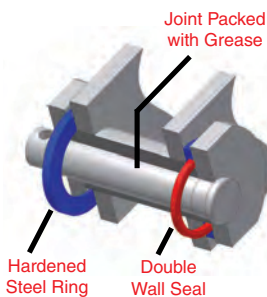

## Allied-Locke Factory Lubricated Sealed Joint Elevator Chain

Allied-Locke's special seals retain factory applied grease while keeping abrasive materials out of the chain joints. The hardened steel rings hold the seals in place and protect them from damage caused by abrasive materials. The effect of this system is longer chain life through reduced wear in the pin-to-bushing contact area. Our standard seal is rated for temperatures up to 250 degrees. Special seals rated up to 400 degrees are also available.

## Sidebars

**Sidebar Holes** are specially processed to provide 100% bearing surface and a smooth finish. This will provide high interference fits to ensure retention and enhance fatigue resistance.



## Pins

**Full Round Pins** and bushings are used to eliminate sharp corners that result in stress risers. Full round pins provide the maximum shear cross sectional area, for the greatest possible tensile strength.



# CEMENT ELEVATOR CHAIN ATTACHMENTS

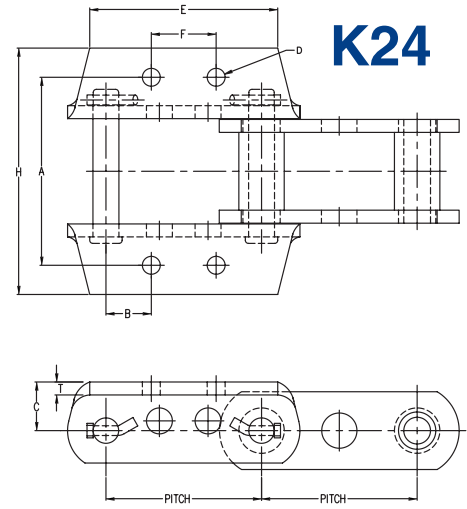
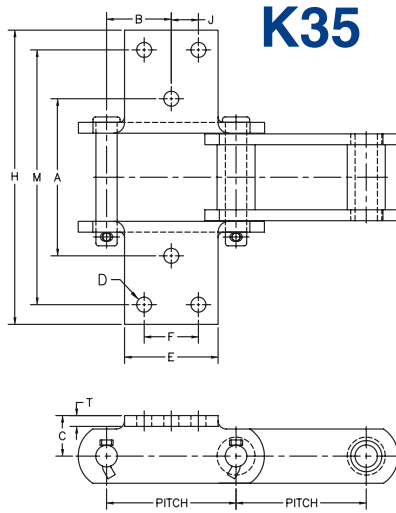
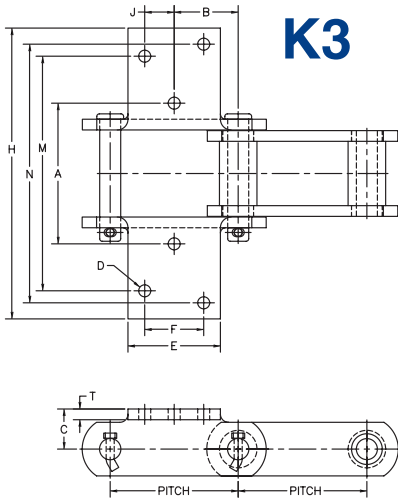

**K44 SS857,  
SS958, SS958SJ**

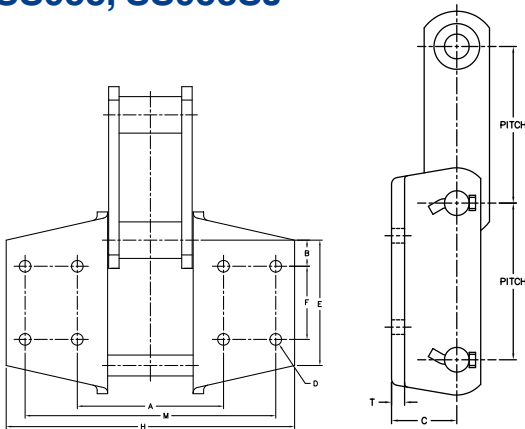

**K44 SS859**

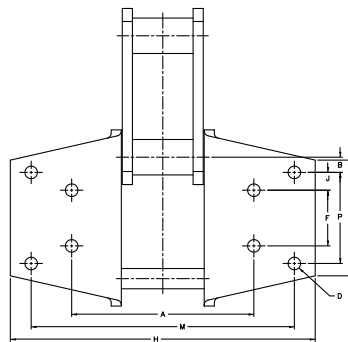

**K443**

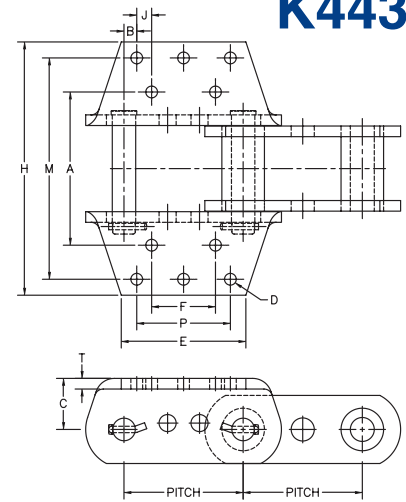

ATTACHMENT STYLE	CHAIN NO.	PITCH	A	B	C	D	E	F	H	J	M	P	T	AVE. WT. PER FT./LBS.
K3	SS856	6.000	6.56	3.00	1.88	.56	4.25	2.75	13.56	1.38	10.94	—	.50	27.3
K24	SS856	6.000	7.25	1.75	1.88	.69	4.25	2.50	9.06	—	—	—	.50	23.0
	SS956	6.000	7.25	1.75	1.88	.69	7.25	2.50	9.50	—	—	—	.50	23.0
K35	SS856	6.000	7.25	3.00	1.88	.69	4.25	2.50	13.56	1.25	11.75	—	.50	27.3
	SS857	6.000	7.25	3.00	1.88	.69	4.25	2.50	13.56	1.25	11.75	—	.50	36.3
K44	SS857	6.000	7.00	1.25	2.50	.56	6.00	3.50	13.81	—	12.00	—	.50	42.0
	SS859	6.000	9.00	.75	3.00	.69	6.75	2.75	15.06	.88	13.00	4.50	.62	68.0
	SS958	6.000	7.00	1.25	2.50	.56	5.75	3.50	13.68	—	12.00	—	.50	40.0
	SS958SJ	6.000	7.00	1.25	2.50	.56	5.75	3.50	14.18	—	12.00	—	.50	40.0
K443	SS864	7.000	9.00	.75	3.00	.69	7.00	3.75	15.00	.88	13.00	5.50	.62	55.0
	SS864SJ	7.000	9.00	.75	3.00	.69	7.00	3.75	15.00	.88	13.00	5.50	.62	55.0
	SS984	7.000	9.00	.75	3.00	.69	7.38	3.75	14.88	.88	13.00	5.50	.62	58.0
	SS984SJ	7.000	9.00	.75	3.00	.69	7.50	3.75	14.88	.88	13.00	5.50	.62	58.0
	SS994	7.000	9.00	.75	3.00	.69	7.50	3.75	14.88	.88	13.00	5.50	.62	58.0
	SS994SJ	7.000	9.00	.75	3.00	.69	7.50	3.75	14.88	.88	13.00	5.50	.62	58.0

\*N = 12.06

# FABRICATED STEEL DRAG CHAIN

ALLOY STEEL • STAINLESS STEEL

Upgrade your heavy duty drag chain to an Allied-Locke fabricated version, designed to increase chain life and reduce down time.



## Fabricated Steel Drag Chain features:

- Hard surface weld on the sliding surfaces of the chain is standard. Weld has a typical hardness of 65 Rockwell, giving the chain enhanced wear in clinker applications.
- The interference fit between the pin and sidebar pin hole lends itself to higher strength, leading to longer chain life as compared to a cast drag chain with slip fit joints.
- Pins are induction hardened, which gives them a hardened outer shell and a thru-hardened core. This gives the pins maximum fatigue resistance.
- Edges of the wings and sidebars are square for more efficient conveying, in comparison to the more rounded cast chain edges.
- Hot rolled and cold rolled alloy steel components eliminate the potential failures that cast chains may experience, due to porosity and casting inclusions.

CHAIN NO.	PITCH IN INCHES	RECOM. WORKING LOAD LBS.	PIN LENGTH F	LENGTH OF BEARING B	MAX ALLOW. SPROCKET FACE E	WING THICKNESS C	SIDEBAR HEIGHT G	PIN DIA. D	A	AVG. WEIGHT PER FT LBS.
WHX1963	9.000	27,600	16.20	12.44	9.38	2.00	2.50	1.25	18.00	54.00
WHX1967	9.000	27,600	16.20	12.44	9.38	2.00	2.50	1.25	20.00	55.00
WHX1976	12.000	42,900	23.64	17.88	15.13	1.13	2.75	1.38	25.88	70.20

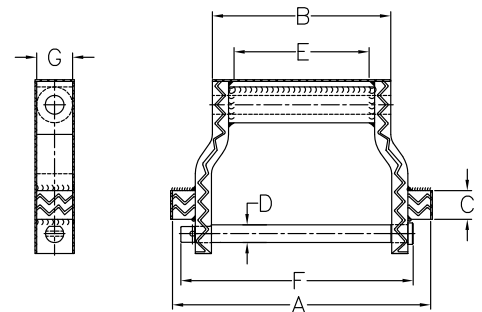

CHAIN NO.	PITCH IN INCHES	RECOM. WORKING LOAD LBS.	PIN LENGTH F	LENGTH OF BEARING B	MAX ALLOW. SPROCKET FACE E	WING & SIDEBAR THICKNESS C	SIDEBAR HEIGHT G	PIN DIA. D	AVAILABLE IN 2" INCREMENTS A	AVG. WEIGHT PER FT LBS.
WHX5157	6.050	18,200	6.94	4.63	2.75	.63	2.50	1.13	8-14	25-31
WHX6067	9.000	24,320	8.12	5.56	3.62	.75	2.50	1.25	10-26	31-47
WHX6121*	9.000	27,600	9.75	6.31	3.62	1.12	2.50	1.25	10-30	40-57

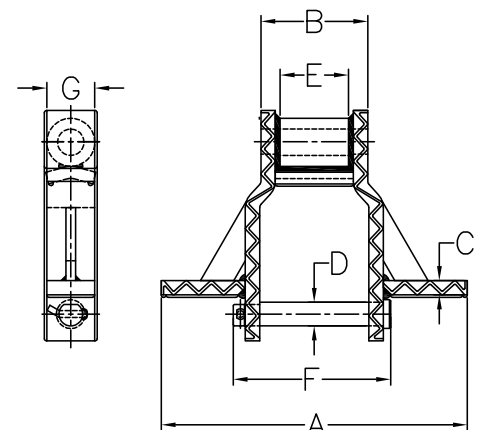

\* WHX5121 is available and operates closed end forward. It is dimensionally similar to WHX6121 except for bushing face plate location due to direction of travel.

# HEAVY DUTY CAST STEEL DRAG CHAIN

ALLOY STEEL • MANGANESE STEEL • STAINLESS STEEL

## S TYPE

**Plow Shape Design** - The complete link including the barrel, wings and sidebars are plow-shaped for improved material handling efficiency.

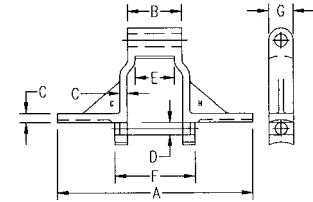

CHAIN NO.	PITCH IN INCHES	RECOM. WORKING LOAD LBS.	PIN LENGTH F	LENGTH OF BEARING B	MAX ALLOW. SPROCKET FACE E	WING & SIDEBAR THICKNESS C	SIDEBAR HEIGHT G	PIN DIA. D	I.E. 8, 12, 14, ... A	AVG. WEIGHT PER FT LBS.
S5157	6.060	18,200	6.94	4.63	2.75	.63	2.50	1.13	8-14	25-31
S5121	9.000	27,600	9.75	6.31	3.62	1.12	2.50	1.25	10-30	40-57
S6121	9.000	27,600	9.75	6.31	3.62	1.12	2.50	1.25	10-30	40-57
S6067	9.000	24,320	8.12	5.56	3.62	.75	2.50	1.25	10-26	29.7-43.3

## HD TYPE

**Maximum Wear** - Cast alloy steel construction, heat treated for greater strength and longer life. Cast manganese steel construction is also available.

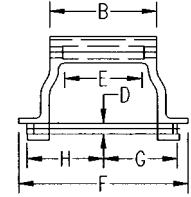
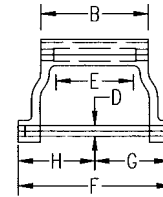
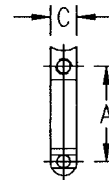

STYLE 1

STYLE 2

CHAIN NO.	STYLE NO.	PITCH IN INCHES A	AVER. WEIGHT PER FT. IN LBS.	WT. PER PIN	BARREL LENGTH B	SIDEBAR WIDTH C	PIN DIA. D	MAXIMUM SPRKT. WIDTH E	MAXIMUM O.A. WIDTH F	PIN HEAD TO CENTER LINE G	PIN END TO CENTER LINE H
1924	1	5.000	19.4	.9	7.62	1.62	.75	6.00	10.12	4.69	5.06
1932	1	6.000	24.2	1.0	5.25	2.00	1.00	3.75	8.00	4.00	4.00
1934	2	6.000	15.2	2.0	5.31	1.56	.75	4.12	7.50	3.69	3.81
1952	1	9.000	27.5	2.5	5.12	2.50	1.12	3.00	9.00	4.25	4.62
1953	1	9.000	30.8	3.0	6.88	2.50	1.12	4.75	10.00	4.81	5.00
1955	1	9.000	36.1	3.0	8.50	2.50	1.12	5.75	12.00	5.78	5.97
1958	1	9.000	39.5	4.5	8.50	2.50	1.25	5.75	12.00	5.78	5.97
1960	1	9.000	45.9	4.3	9.25	2.50	1.25	6.50	14.00	6.75	7.12
1962	1	9.000	46.8	5.9	12.44	2.50	1.25	10.25	16.38	7.84	8.34
1964	1	9.000	52.2	6.0	12.69	2.50	1.25	10.00	18.00	8.82	9.03
1965	2	9.000	50.1	6.0	12.44	2.50	1.25	10.25	18.38	7.84	8.34
1967	2	9.000	55.5	6.0	12.69	2.50	1.25	10.00	20.00	8.82	9.03
1972	1	12.000	63.2	10.0	17.88	2.75	1.38	14.38	24.00	11.38	11.88
1976	2	12.000	70.2	10.0	17.88	2.75	1.38	14.38	26.00	11.38	11.88

\* Steel fabricated versions are also available, as shown at the right.



## SD TYPE

**Hardsurfacing** - An Allied-Locke standard on all types of drag chain, providing additional wear life on critical sliding surfaces.

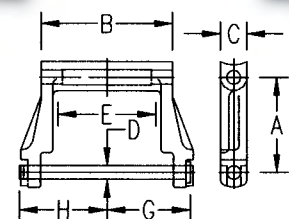

CHAIN NO.	PITCH IN INCHES A	AVER. WEIGHT PER FT. IN LBS.	WT. PER PIN	BARREL LENGTH B	SIDEBAR WIDTH C	PIN DIA. D	MAXIMUM SPRKT. WIDTH E	MAXIMUM O.A. WIDTH F	PIN HEAD TO CENTER LINE G	PIN END TO CENTER LINE H
SD21	9.000	46.8	6.0	12.44	2.50	1.250	9.50	—	8.19	8.31
SD23	9.000	41.8	4.2	8.44	2.50	1.250	5.75	—	6.00	6.00
SD27	9.000	30.7	2.9	6.88	2.50	1.125	4.25	—	4.81	5.06
SD28	9.000	26.0	2.8	12.81	2.12	.875	10.12	—	8.00	8.12
SD29	9.000	20.8	2.5	8.81	2.12	.875	6.25	—	6.00	6.12

*"Experience The Allied-Locke Advantage... Today"*

# SPECIALTY CHAINS AND BUCKETS

## Super Capacity Dual Strand Elevator Chain

Dual strand chains have been developed to meet the need for greater conveying capacity. Allied-Locke manufactures these chains to the same high standards as our standard elevator chains. Shown below are these chains with the typical G5 attachment. Allied-Locke also offers buckets for these chains.

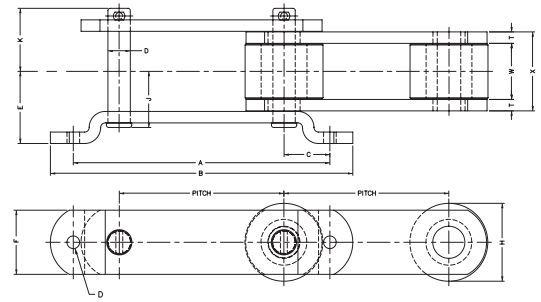

CHAIN NO.	ATTACHMENT STYLE	PITCH	A	B	C	BOLT DIA.	HOLE DIA.	D	E	F	H	J	K	W	T	X	AVE. WT. PER FT./LBS.
MSR4004	G5	9.000	14.00	16.50	2.50	.62	.69	1.00	3.34	2.50	3.00	2.60	2.91	2.62	.50	3.62	19.7
MSR4009	G5	9.000	14.00	16.50	2.50	.62	.69	.88	3.03	2.50	3.00	2.22	2.50	2.25	.38	3.00	14.7
MSR4065	G5	9.000	14.00	16.50	2.50	.62	.69	1.25	3.94	3.50	4.25	3.06	3.44	3.06	.62	4.31	40.0

## Reclaimer Chains

Raw Material handling in most facilities incorporates a stacker-reclaimer system, made by one of a wide variety of manufacturers. Allied-Locke has engineered and fabricated a wide range of reclaimer chains to match and replace the chains currently in use in cement plants.

Because of the variety of styles of this chain in use, it is hard to identify a "standard" chain. Shown below are a few examples of the more common stacker-reclaimer chains that have been manufactured by Allied-Locke. We can duplicate most any style and merely require a sample or drawing of the existing chain in use. Let Allied-Locke Industries be your source for your reclaimer chain and sprocket needs.

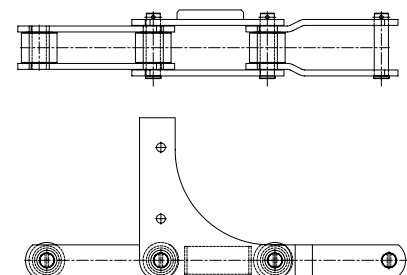
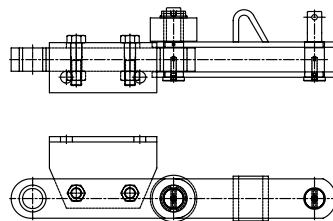
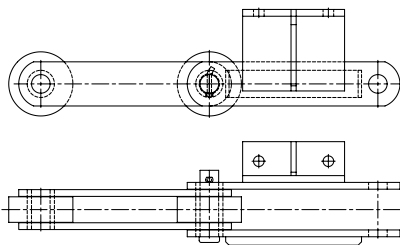

## Elevator Buckets

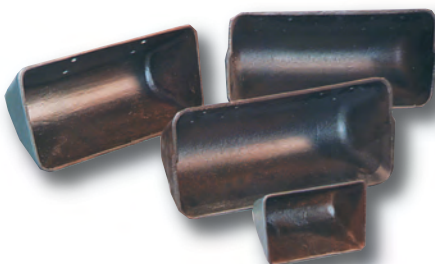

**ALLIED-LOCKE** offers all styles of elevator buckets in fabricated steel, cast malleable, and cast promal.

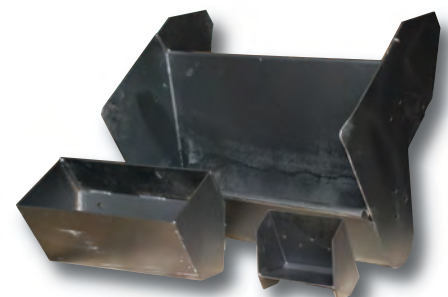

# SPROCKETS

## Split Segmental Rims for HD and SD wide series drag chains

Allied-Locke Industries' innovative design helps to save time and money during installation of the sprocket without losing sprocket integrity. Sprocket teeth are made of alloy steel and are heat treated to perform in the most severe applications. Bodies are made of medium carbon steel and include mounting hardware.

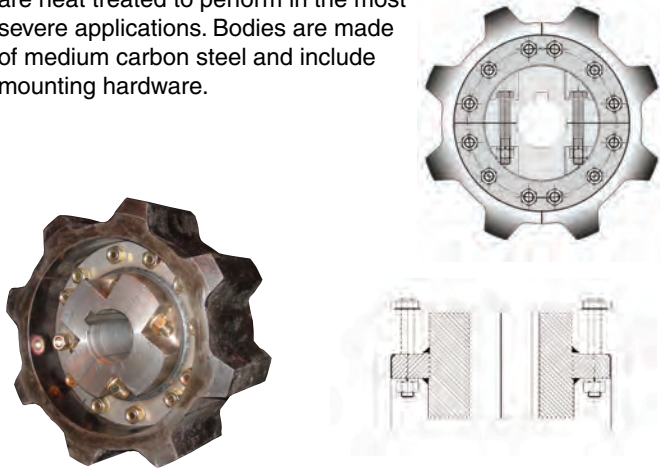

## Fabricated Steel Segmental Traction Wheel Rims for Elevator Chains

Rims are made of alloy steel and are hardened for severe duty. Wear on the chamfered rim acts as a signal for time of replacement. Grade 8 bolts are utilized to hold rims to bodies

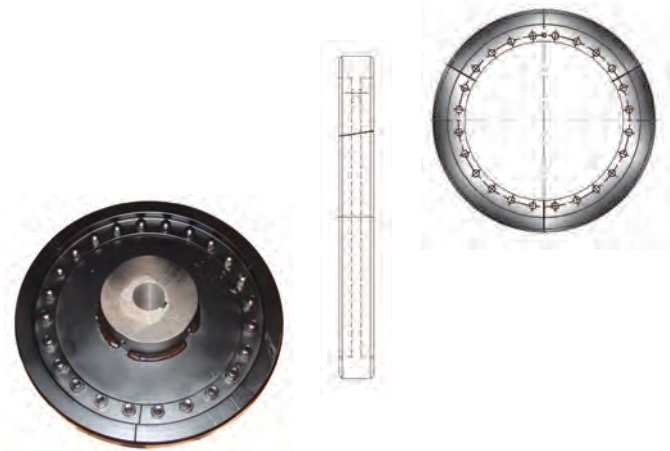

## Fabricated Steel Segmental Sprocket Rims for Elevator Chains

Rims are made of alloy steel and are heat treated for maximum wear and strength. Grade 8 bolts are used to hold rims to bodies.

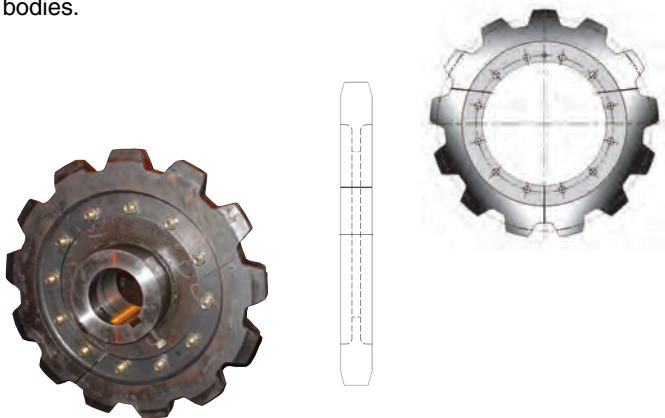

## Fabricated Steel Split Bodies

Bodies are made of medium carbon steel for durability. All grade 8 hardware used for holding split body halves together.

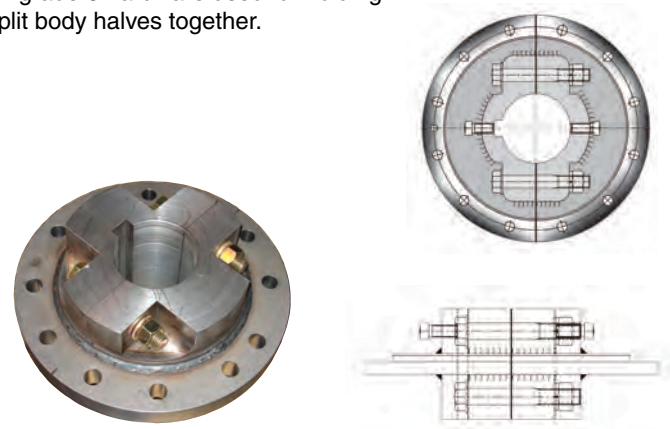

## FEATURES

- ★ Sprocket teeth are profiled for smooth engagement and disengagement.
- ★ Segmental rims are manufactured to perform according to the application.
- ★ Bodies are manufactured from medium carbon steel.
- ★ Grade 8 hardware is used to hold split body halves together.
- ★ Grade 8 hardware is used to hold rims on to bodies.
- ★ Huck fasteners are available.

**ALLIED-LOCKE INDUSTRIES, INC.**

**800.435.7752 - TOLL FREE PHONE**

**800.462.3130-FAX**

**info@alliedlocke.com**

**www.alliedlocke.com**



CS172 Rev. 01/2026

**www.alliedlocke.com**